

Woodland Eco Towers - Holt Plus (Plastic Slide)

QWDHOL005



Play Value



Materials & Guarantees

Timber Poles (Out of Ground) - 20 Years
Steel Ground Fixings - 20 Years
Structural Stainless Steel - 25 Years
Sawn Timber - 15 Years
Colour Coated Steelwork - 5 Years
Compact Grade Laminate - 10 Years
Plastic Slides - 5 Years
Bolts - 10 Years
Plastic Components - 5 Years

- 1.1m Tower
- 1.1m Plastic Slide
- 1.1m Inclined Access
- 1.1m Scramble Net
- Pull-Up Bar
- Noughts & Crosses Play Panel

Experience the all-in-one playground joy with The Holt Plus! This single-play tower combines essential and simplified climbing sliding swinging and social play features ensuring endless enjoyment for all ages.



WOODLAND ECO TOWERS



Fixing Options

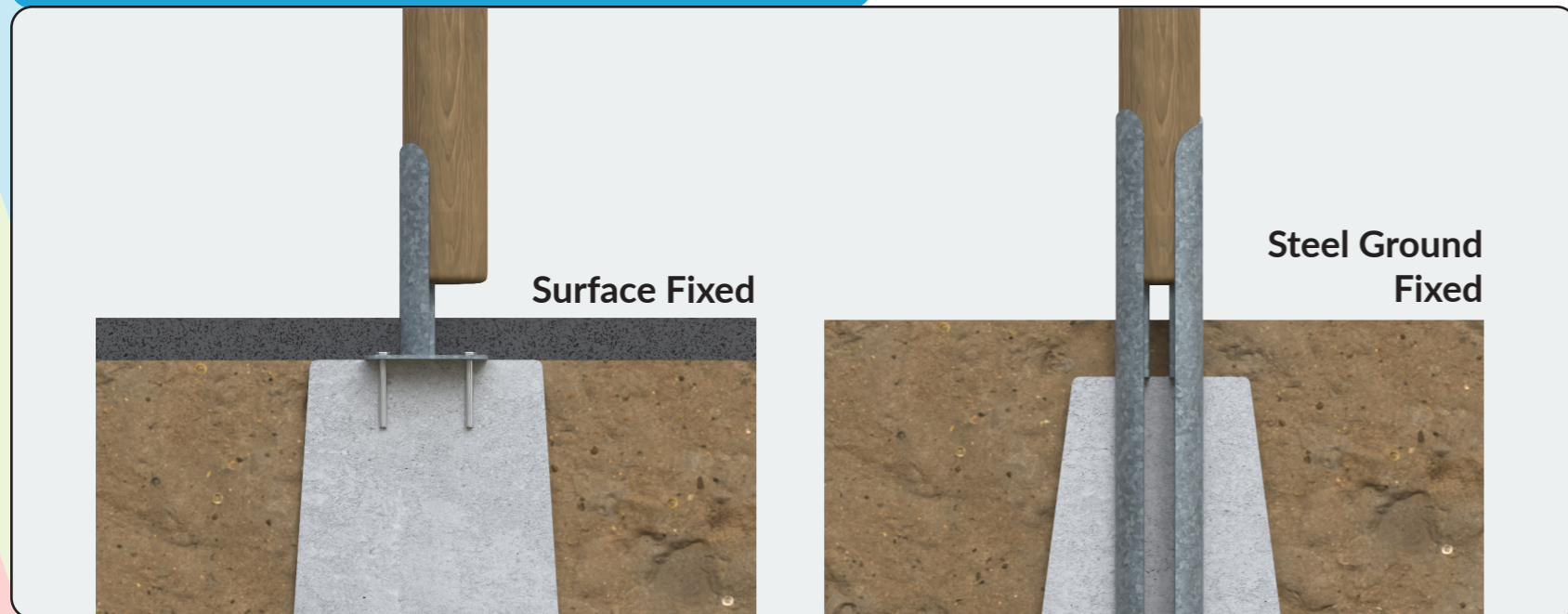

Roof Options



Equipment Dimensions

Length / Width / Height	3.5m x 4.9m x 2.9m
-------------------------	--------------------

Surfacing and Area Required

Recommended Minimum Space	7.1m x 8.8m x 4.1m
Max Gradient of Ground	1 in 50
Free Height of Fall	1.6m
Synthetic Surfacing Area	32m ²
Loosefill @ 250mm Depth	11.5m ³
Grasslok (1m x 1m Tiles)	43.5m ²

Installation Information

Installation Time	2 Persons 12 Hours
Overall Weight	259kg
Heaviest Part	32kg
Largest Part	2.4m x 0.6m x 0.5m
Longest Part	2.9m
Concrete Required	0.7m ³

Plan View

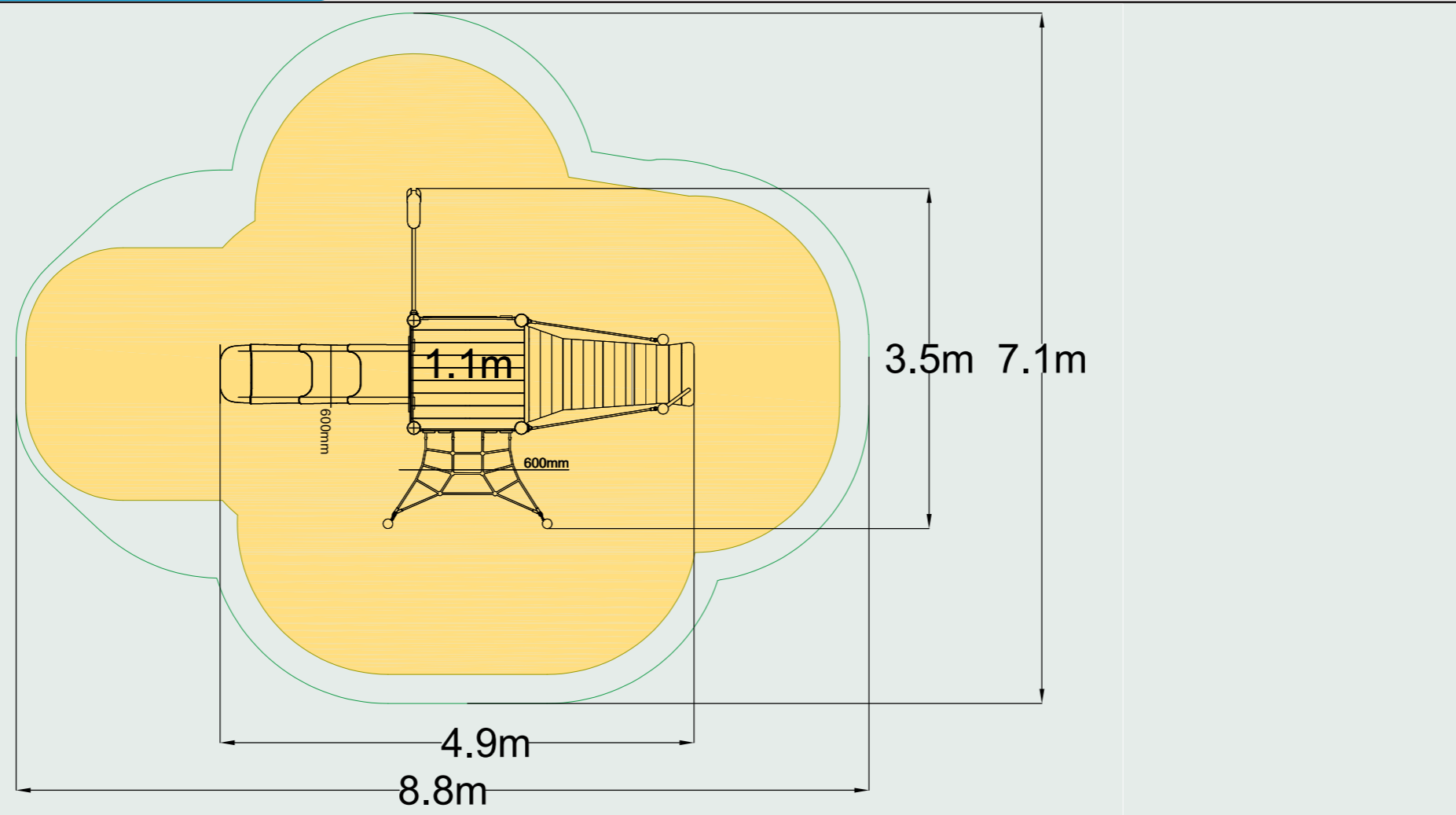

EN1176
Impact Area



Recommended
Minimum Space

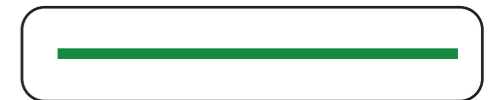

Free
Space



Synthetic
Surfacing

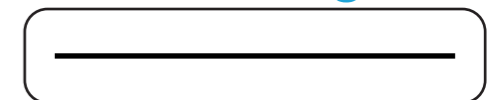

Side Elevation

